



S18 UC

UNDERCOUNTER VERSION



Expect more with this high-capacity solution that delivers **premium chilled, sparkling, and ambient water on demand.**

This advanced system produces up to 180 liters per hour* of premium chilled, sparkling, and ambient water, perfect for high volume applications including hotels and restaurants.

Featuring an 11" dispense height, rapid cold carbonation, and manual faucets for dependable dispensing, the S18 UC makes quick, efficient bottle-filling an easy task for any user.

System Highlights:

- 3-tap chrome dispensing tower features chilled, sparkling, and ambient water
- 4-Stage advanced filtration system can be easily mounted to chiller or installed remotely
- Carbonating chiller and purification system installs remotely or under counter
- Insulated trunkline and water recirculation to ensure optimal temperature from chiller to tap



*Capacity dependent on source water temperature

The S18 UC sets itself apart as a **high-end, space-saving system** delivering generous capacity and exceptional **still and sparkling water.**

Features:

- Unrivaled 22lb ice bank chills a higher volume of cold water
- Utilizes R290 environmentally friendly natural refrigerant
- Equipped with a 1.7 liter sparkling tank
- Programmable flow meter tracks usage and allows more consistent scheduled service and filter changes
- Heavy duty rotary faucets allow for pressure and flow control to limit splashing
- Easily connects to external CO2**
- Removable drip tray***

**CO₂ regulator included
 ***Optional recessed drip tray

3-Tap Chrome Tower



Undercounter Chiller

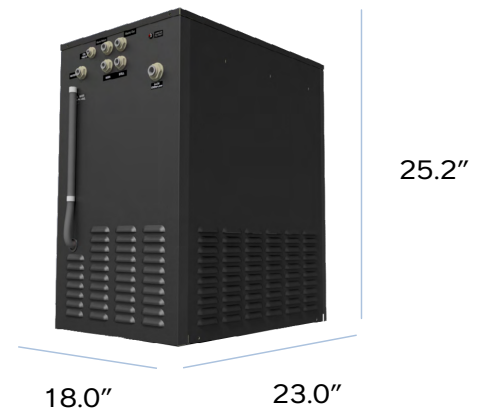

Tap Dimensions	25.5"h x 5.2"w x 22.3"d
Drip tray dimensions	1.3"h x 15.0"w x 5.0"d
Undercounter dimensions	25.2"h x 18.0"w x 23"d – Width includes 4.3" for filtration housing
Ventilation clearance requirement	See detailed installation guide for more information
Dispense height	11.0"h
Tap dry weight	20 lbs
Undercounter dry weight	94 lbs
Tower tap hole size requirement	2.0"
Chilling capacity	180 liters per hour*
Cooling technology	Ice bath chilling technology
Recommended water pressure	50 psi
Ice block weight	22 lbs
CO2 specificatio	Available external CO2 tank or bulk CO2 supply connection; Operates at 55 PSI
Rated voltage/frequency / running amps	115 V / 60 Hz / 7 amps
Model number	S18 UC

*Capacity dependent on source water temperature



630 Allendale Road, Suite 200
 King of Prussia, PA 19406
 855.474.7934
 PureWaterTech.com

Certified by IAPMO in accordance with ANSI/NSF 372 for lead free products and certified by IAPMO R&T in accordance with UL 399 and CSA 22.2 for electrical safety. NSF61, CSA B483.1

Installation Guide

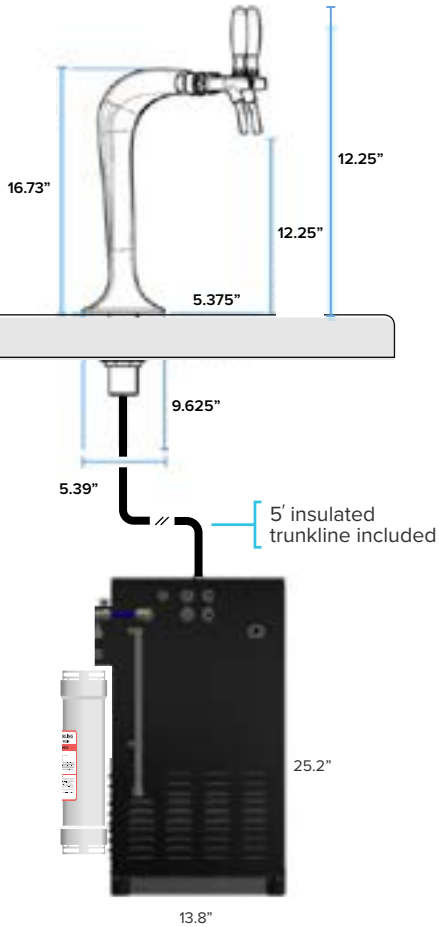

Detachable Filter Set

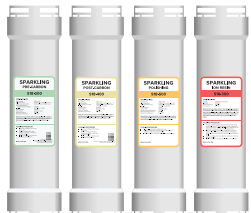

Filter Dimensions

Height	18.0"
Width	4.5"
Depth	20.0"

System Details

The following components are mandatory for proper efficiency and prevention of leak damage risk. These items are not included with the provided equipment:

Safety Pan

- Provides protection of water damage to the floor of the cabinet.

Leak Detection

- Provides notification of water leaks in non-visible cabinets.

Ventilation Details

Proper air flow is essential for optimum performance. Fresh air **must** have a direct path to the chiller. Hot air **must** exhaust away from the cabinet using the recommended open door or ventilation gate method.

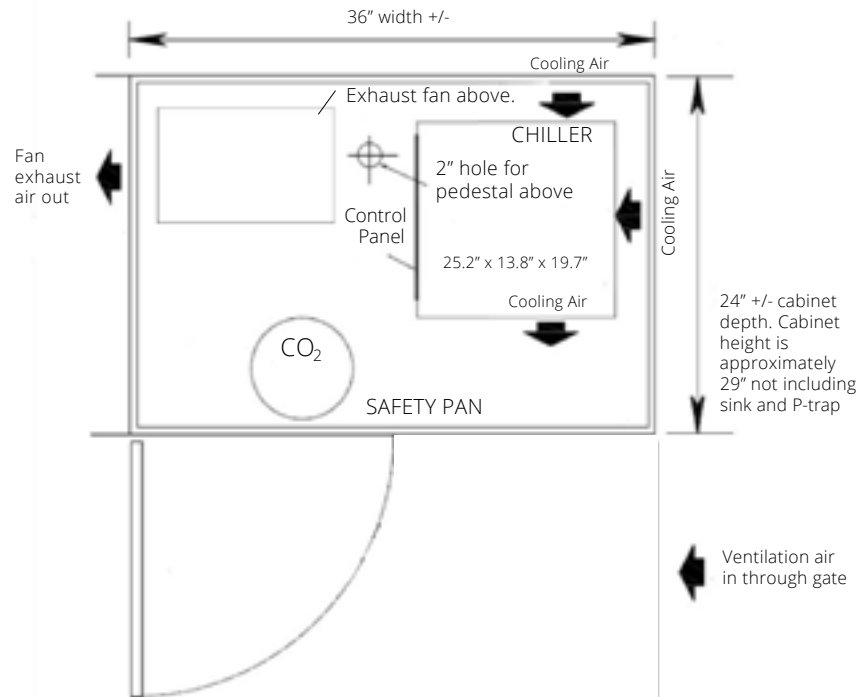
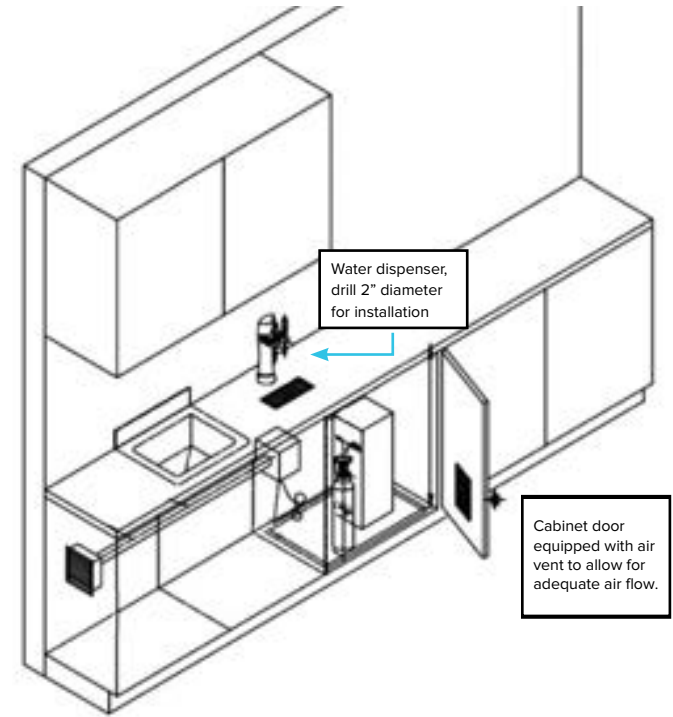

Top View

- 4" minimum clearance all around chiller to allow for proper cooling.
- For installation in existing cabinets, adjust dimensions as required.
- Water bath condensation line must be directed to a drain or bucket.
- Electrical outlet is required for under the counter applications.